

ACHIEVING PRECISE FLOW IN FUSED DEPOSITION MODELING EXTRUDERS

by

William K. Langford

Term Paper

Engineering Management 52
Tufts University
Medford, Massachusetts

March 11, 2012

**This page has been
intentionally left blank.**

EXECUTIVE SUMMARY

I'm writing this paper in the spring of 2012 as a term paper for Engineering Management 52, Technical and Managerial Communication, taught by Professor Amy Hirschfeld at Tufts University in Medford, Mass.

The purpose of this paper is to inform the reader about some of the challenges involved in achieving consistent, precise control of the flow of molten thermoplastic in the fused deposition modeling process, and to provide an overview of counter measures that can be made in both the mechanical design and control design to compensate for undesirable flow characteristics.

I (1) provide the reader with an overview of the role of the extruder in the fused deposition modeling process, (2) reveal the need for precise thermoplastic flow control, (3) present a dynamic model of the flow, (4) explain the trends identified in the dynamic model with theoretical relationships, and (5) discuss methods of improving flow control in both the mechanical design and control design of a thermoplastic extruder.

Fused deposition modeling is a process by which physical objects can be made from three-dimensional virtual designs; it involves moving a thermoplastic extruder over a build surface to deposit thin strands of plastic and build the object layer by layer.

The fused deposition modeling process is increasingly being used for manufacturing consumer goods, warranting an improvement in the quality of the 3D printed object output. Because the thermoplastic extruder is the least understood component of the system, it is a logical place to look for improvements.

The molten plastic flow characteristics of thermoplastic extruders is not trivial. By dynamic modeling the flow characteristics with experimental data, three parameters are found to describe the flow characteristics of any given extruder: the equivalent gain, the equivalent time constant, and the equivalent delay constant.

In referencing the trends described by the dynamic model with theoretical relationships, we can target specific methods to improve flow control in both the mechanical and control design areas.

In terms of mechanical design, the size and tolerance of the filament diameter is found to play a very significant role in determining flow characteristics of the extruder. By reducing the diameter and manufacturing the filament with tighter tolerances, a drastic reduction in volumetric flow error can be achieved.

In terms of control design, a number of techniques can be used to compensate for the inherent flow characteristics of any given extruder. By incorporating the dynamic model as a predictive step in the control scheme, a much greater control over the thermoplastic flow rate can be had.

TABLE OF CONTENTS	
EXECUTIVE SUMMARY	ii
LIST OF FIGURES	iv
LIST OF ABBREVIATIONS, ACRONYMS, AND INITIALISMS	vi
SYMBOLS	vii
1.0 INTRODUCTION	1
1.1 Purpose	1
1.2 Scope	1
2.0 BACKGROUND	1
2.1 Introduction to Fused Deposition Modeling	1
2.2 The Role of the Extruder in the FDM process	2
2.2.1 Introduction to FDM extruders	2
2.2.2 Primary components of an FDM extruder	3
2.2.3 Survey of existing FDM extruder technologies	4
2.3 Precise Flow Control in the FDM process	4
2.3.1 The need for precise flow control in the FDM process	4
2.3.2 Challenges in achieving precise flow control in the FDM process	5
3.0 DETERMINATION OF FLOW CHARACTERISTICS IN AN FDM EXTRUDER	5
3.1 Dynamic Modeling of the Liquefier	5
3.2 Experimental Determination of the Dynamic Model of a Makerbot StepStruder [®]	6
4.0 THEORETICAL INVESTIGATION OF THE CAUSES OF IMPRECISE FLOW	7
4.1 Theoretical Contributions of the Thermoplastic Filament to FDM Flow Errors	7
4.2 Theoretical Contributions of Mechanical Design to FDM Flow Errors	8
5.0 PRACTICAL METHODS OF ACHIEVING MORE PRECISE FLOW CONTROL	9
5.1 Mechanical Design Considerations in Achieving More Precise Flow Control	9
5.2 Control Design Considerations in Achieving More Precise Flow Control	10
6.0 CONCLUSIONS	11
LIST OF REFERENCES	
FIGURES	

LIST OF FIGURES

- 1 Visual depiction of the FDM process
- 2 Stratasys drawing illustrating realistic flow characteristics of an FDM extruder
- 3 Experimental test setup to determine the dynamic model of a Makerbot StepStruder[®] MK6
- 4 Experimental test data of the Makerbot StepStruder[®] MK6 with a dynamic model overlaid (Test #4). [Left] Volume vs. Time simulation, [Right] Flowrate vs. Time simulation
- 5 Plot of all fifteen dynamic model simulations derived from experimental trials with the Makerbot StepStruder[®] MK6
- 6 Stratasys Inc. drawing illustrating movement of the melt flow inside a hot-end during changes in flow rate
- 7 Stratasys graphs showing a control technique to compensate for flow characteristics
- 8 Stratasys graph showing an ideally compensated extrusion

LIST OF DEFINITIONS

Extruder	A device used to deposit thermoplastic in the fused deposition modeling process.
Liquefier	Synonymous with extruder.
Thermoplastic	A plastic that softens when heated.
Stratasys Inc.	The pioneering company of fused deposition modeling.
Makerbot Industries	A startup 3D printing company that makes low(er) cost fused deposition modeling machines.
Filament	The raw material feedstock used in the fused deposition modeling process.
Steady state	A system that has reached equilibrium and is not changing with time.
Viscosity	The thickness of a fluid. (Water is not very viscous whereas honey is.)
StepStruder [®]	Makerbot Industries' coined term for an extruder that uses a stepper motor to drive the filament.

LIST OF ABBREVIATIONS, ACRONYMS, AND INITIALISMS

FDM	Fused Deposition Modeling
ABS	Acrylonitrile Butadiene Styrene
rpm	revolutions per minute
CAD	Computer Aided Design

SYMBOLS

μ	equivalent gain
T	equivalent time constant
τ	equivalent delay constant
ΔS_g	average movement of the melt-zone inside the hot-end
σ_F	standard deviation of filament diameters
d_T	mean (target) filament diameter
V_{error_FD}	volumetric flow error due to filament diameter tolerances

1.0 INTRODUCTION

1.1 Purpose

The purpose of this paper is to inform the reader about some of the challenges involved in achieving consistent, precise control of the flow of molten thermoplastic in the fused deposition modeling process, and to provide an overview of counter measures that can be made in both the mechanical design and control design to compensate for undesirable flow characteristics.

1.2 Scope

In this paper, I (1) provide the reader with an overview of the role of the extruder in the fused deposition modeling process, (2) reveal the need for precise flow control in the thermoplastic extrusion process, (3) demonstrate the process of experimentally determining flow characteristics, (4) give an overview of the theoretical causes and explanations of undesirable flow characteristics, and (5) discuss methods of improving flow control in both the mechanical design and control design of a thermoplastic extruder.

The discussion in this paper is limited to extruders that use ABS (Acrylonitrile butadiene styrene) plastic in the fused deposition modeling process because ABS is an industry-standard thermoplastic extrusion material and much of the same findings can easily be applied to extruders of other thermoplastics.

2.0 BACKGROUND

2.1 Introduction to Fused Deposition Modeling

Fused Deposition Modeling, or FDM, is a process by which physical objects can be made from virtual three-dimensional CAD (Computer Aided Design) models. It is an additive manufacturing technique, which means that objects are built layer by layer. During the process, a

thermoplastic¹ extruder is used to deposit small beads (or strings) of plastic to draw a picture as it is moved over the build surface. Once the layer is complete, the build-platform lowers one layer height and the extruder draws the next layer—depositing plastic that fuses to the previous layer. This process is repeated until the complete three-dimensional plastic object is built such that it closely resembles the original CAD model. Figure 1 presents a good visual depiction of this process. Bre Pettis, CEO of Makerbot Industries, often describes how the 3D printing² (or FDM) process works like this:

The machine works like a super accurate automated hot glue gun robot. It takes a filament of plastic and melts it down and extrudes it through a tiny hole to make a tiny string of molten plastic. Layer by layer it builds up material until your object is complete! [1]

Fused deposition modeling has been traditionally used only to rapidly prototype designs; recently though, there has been a push to use the fused deposition modeling process to manufacture end products. For this move from prototyping to manufacturing to be successful, the quality of the 3D printed object needs to improve. [2] There are a number of ways that this quality improvement is being made, but improvements in the design and implementation of thermoplastic extruders is perhaps the most obvious and most direct method.

2.2 The Role of the Extruder in the FDM process

2.2.1 Introduction to FDM extruders

The extruder in the fused deposition modeling process is responsible for taking raw plastic filament, heating it up, and extruding it through a tiny nozzle to deposit thermoplastic material on the build-surface.

¹ A thermoplastic is a plastic that softens when heated.

² For the purposes of this paper, 3D printing is synonymous with the FDM process.

² For the purposes of this paper, 3D printing is synonymous with the FDM process.

In many ways FDM extruders are the least understood and most complicated parts of a 3D printer. While gantry systems (that position the extruder and move it around to draw each layer) are very well established and have existed since the 1800's, thermoplastic extruders for use in 3D printers are relatively novel, having been first developed by Stratasys Inc. in the late 1980's. [3] Despite the extruder's complication though, every extruder is comprised of a few standard primary components.

2.2.2 Primary components of an FDM extruder

There are two primary components of an FDM thermoplastic extruder: the filament drive mechanism and the heated nozzle, or hot-end.

The filament drive mechanism is what drives the raw plastic filament into the heated nozzle. It is usually comprised of an actuator like an electric motor and a drive gear to grip the filament and translate the rotational motion of the actuator into linear motion of the filament. The drive mechanism needs to be powerful enough to force the plastic filament through the heated nozzle, or hot-end.

The hot-end is what the raw filament finally passes through before being deposited in the fused deposition modeling process. It is comprised of a heater, a temperature sensor, and a fine-tipped nozzle. The hot-end accepts filament (often at a nominal diameter of 1.8mm) and extrudes the melted thermoplastic through the nozzle tip, which is usually on the order of 0.3mm. The temperature sensor is used to provide feedback to the controller such that the temperature can be regulated to a certain temperature. [4]

2.2.3 Survey of existing FDM extruder technologies

Every fused deposition extruder implements both a filament drive mechanism and a hot-end but there are many variations of the implementations in various existing extruder designs.

The Makerbot StepStruder[®] MK8, which is featured on Makerbot Industries' latest 3D printer, has gone through eight public revisions and is now a well-established design. It uses a stepper motor to directly drive the filament (with a custom-made drive gear) and force the filament through a small thermal block (heated to 220°C) and out of a 0.4mm brass nozzle.

Stratasys Inc. uses a slightly different filament drive mechanism in one of their extruders. Instead of directly driving the filament with a drive gear attached to a stepper motor, its extruder uses an internally threaded pulley to drive the filament; that is to say, a motor actuates the pulley with a belt such that the internal threads of the pulley force the filament downward (into the hot-end). This design ensures that the drive gear (or pulley in this case) is always in good contact with the filament because of the tension exerted by the belt on the pulley. It also provides significant mechanical advantage such that much greater forces can be generated to push the filament. [5]

2.3 Precise Flow Control in the FDM process

2.3.1 The need for precise flow control in the FDM process

Precise flow control in FDM extruders is necessary to ensure the quality of the parts made during the 3D printing (or FDM) process. The fused deposition modeling technology is being pushed to achieve greater-and-greater quality parts as the transition is made from purely producing prototypes to manufacturing consumer-end products.

An extruder with perfect control of the flow of plastic is expected to have an output flow rate exactly equal to the commanded, or desired, flow rate. In a more realistic case, the extruder

is told to extrude at a certain flow rate but is unable to exactly match the desired flow rate at every point in time.

To create sub-millimeter scale features in 3D printed parts, one has to have good control of the thermoplastic flow from an extruder. This control of the flow in an extruder is not trivial to achieve and there are many challenges and effects to be considered that make obtaining good flow control difficult. Zinniel et al. says (in a patent assigned to Stratasys Inc.), “An uncontrolled flow rate, even when the fluctuations are small, can contribute to large variations in the quality of the final model, including gaps and excess thickness.” [6]

2.3.2 Challenges in achieving precise flow control in the FDM process

The mismatch between desired flow rate and actual flow rate manifests itself in the flow characteristics of an FDM extruder. There are three primary characteristics of molten plastic flow that dominate the extrusion process: the time it takes for the flow rate to ramp up/down, steady state³ flow rate offsets, and delays in the flow rate response; the first two characteristics can be seen in the line labeled “actual flow” of the Stratasys Inc. patent drawing reproduced in Figure 2. Given that a discrepancy between desired and actual flow exists in FDM extruders, it is necessary to quantify this disagreement in order to eventually take steps to alleviate the issue.

3.0 DETERMINATION OF FLOW CHARACTERISTICS IN AN FDM EXTRUDER

3.1 Dynamic Modeling of the Liquefier

Dynamic modeling, or simulation, is a way to quantify and characterize processes that happen through time. By creating a mathematical model and finding parameters for that model that make

³ Steady state is the term used to describe a system that is no longer changing in time. (It has reached its equilibrium.)

it a good fit for experimental data, the data is able to be characterized and quantified in a consistent way. In the case of thermoplastic extruders, creating a mathematical model is helpful in characterizing how the deposition flow rate changes in response to an input control command (e.g. rotating the extruder drive motor); information about an extruder's flow is incredibly valuable when designing a control system for an FDM process.

Bellini et al. present a dynamic model of the extrusion process in response to a step input in extruder drive motor velocity. The model is presented as the first-order transfer function:

$$G(s) = \frac{\mu}{Ts + 1} \cdot e^{-\tau s} \quad (1)$$

Where μ is the equivalent gain, T is the equivalent time constant, and τ is the equivalent delay. In this case, the equivalent gain is a representation of the steady state flow rate offset, the equivalent time constant is a measure of how quickly the flow rate reaches steady state, and the equivalent delay a measure of how long it takes for the actual extrusion to start after being commanded to start. [7]

3.2 Experimental Determination of the Dynamic Model of a Makerbot StepStruder[®]

3.2.1 Experimental test setup of extruder deposition step response

In the interest of characterizing the ABS deposition flow of a Makerbot MK6 StepStruder[®]⁴. I conducted a series of tests to determine values for the parameters of the first-order dynamic model defined above by Bellini et al. The test involved using a camera to measure the volume of material extruded over time given a step input in desired flow rate. The test setup is depicted in Figure 3. In the test, I activated the extruder for five seconds at a prescribed motor rotational speed. I then found the volume of plastic extruded at every time-step by post-processing the

⁴ StepStruder[®] is the coined term for an extruder that uses a stepper motor.

video and determining the length of extrusion at every frame. I performed a total of fifteen trials at three different motor rotational speeds: 2.0 rpm, 3.0 rpm, and 4.0 rpm.

3.2.2 Results of extruder deposition step response experiment

I analyzed the data and started by finite-differencing the volumetric flow data to obtain a volumetric flow rate versus time (instead of volume extruded versus time). Given the flow rate data, I optimized the fit of the dynamic model simulation from Bellini et al. and determined the values of the transfer function parameters for each trial. It is important to note that the nonlinear delay term ($e^{-\tau s}$) was neglected in this simulation because the experimental test setup ensured a negligible delay between desired and actual flow rate. An example simulation overlaid on actual data is shown in Figure 4. A plot of the collection of all trials is displayed in Figure 5. The data shows that the speed at which the extruder deposits material greatly affects the flow characteristics and dynamic model parameters. While dynamic modeling is helpful in characterizing and quantifying the extruder flow, theoretical analysis is necessary in order to determine potential areas of improvement.

4.0 THEORETICAL INVESTIGATION OF THE CAUSES OF IMPRECISE FLOW

4.1 Theoretical Contributions of the Thermoplastic Filament to FDM Flow Errors

The thermoplastic filament itself has a significant effect on the variability in an FDM extruder's flow. Filament contributes to volumetric flow errors (i.e. errors that result from discrepancies between desired flow rates and expected output flow rates) in two ways.

The first is the variability of the filament diameter. In a patent for high precision modeling filament, Stratasys Inc. derives the contribution of volumetric flow error from variability in the diameter of the filament to be:

$$V_{error_FD} = \frac{3\pi\Delta S_g\sigma_F d_T}{2} \quad (2)$$

Where ΔS_g is the average movement of the melt-zone inside the extruder during a change in flow rate, $\Delta\sigma_F$ is the standard deviation in the filament diameter, and d_T is the mean diameter of the filament. The equation reveals that volumetric flow error is directly proportional to both the standard deviation of the filament diameter, σ_F , and the mean of filament diameter, d_T . [2]

The second is the difference between the extruder's inlet diameter and the filament's outer-diameter. Manufacturing tolerances on the filament diameter prevent the perfect sizing of the hot-end inlet diameter to the filament outer-diameter; instead, a finite gap between the sides of the filament and the inner-face of the hot-end will always exist. This gap creates an interesting issue in terms of flow characteristics. Because the thermoplastic expands as it is heated, the gap is filled partway down the hot-end (where the melt-zone is) but is left empty above the melt-zone. The speed at which the filament is forced into the hot-end determines the size of the melt-zone; that is to say, the faster the filament is pushed, the smaller the melt-zone will be because there is not as much time for the heat to transfer into the thermoplastic. Figure 6 depicts the movement of the melt-zone, which significantly affects the equivalent time constant, T , used in the dynamic model.

4.2 Theoretical Contributions of Mechanical Design to FDM Flow Errors

Looking back at the three parameters that affected the dynamic model of an extruder's flow characteristics: μ (the equivalent gain), T (the equivalent time constant), and τ (the equivalent delay) gives some theoretical insight into why the flow errors exist.

The equivalent time constant (T) is representative of the time it takes the extruder's flow rate to reach steady state. This error is determined primarily by the limitation on the power of the motors and the effect of temperature on the viscosity⁵ of the flow (as we have just discussed).

The equivalent gain (μ) is representative of the steady state flow rate offset of an extruder—that is to say, the actual output flow rate is consistently less than the desired flow rate by some gain, or multiplier, μ . This error is caused primarily by slip conditions between the filament and the drive gear. [8]

Now, given that certain design parameters relate to extruder flow performance, we can access various methods of achieving more precise flow control.

5.0 PRACTICAL METHODS OF ACHIEVING MORE PRECISE FLOW CONTROL

5.1 Mechanical Design Considerations in Achieving More Precise Flow Control

The filament diameter has a significant impact on the design of an extruder looking to exhibit a less significant discrepancy between desired flow rate and actual flow rate. From eq. 2 above, it is clear that the filament diameter contributes to the volumetric flow error associated with the extrusion process; that is, as the filament diameter and standard deviation of the diameter increases, so to does the volumetric flow error. Therefore, it makes sense to minimize the diameter of the filament used and to choose filament with small, precise tolerances; furthermore, the inner-diameter of the hot-end should be made to be as close as possible to the maximum outer-diameter of the filament. Practically speaking, 0.075" (1.8mm) ABS filament is the thinnest extrusion material that is commonly available and so a 0.075" inner-diameter inlet should be considered. [8]

⁵ Viscosity is the measure of the thickness of a fluid. Thus, water has a low viscosity while honey has a higher one.

The filament diameter also contributes to the mechanical design of an FDM extruder in other ways. For one, the amount of torque required of the filament drive motor is very much determined by the filament diameter. This can be explained by the fact that the amount of linear force necessary to push the filament through the heated nozzle is directly proportional to the cross-sectional area of the filament; this relation further implies that the necessary force is directly proportional to the square of the filament's diameter. This means that if one were to double the diameter of the filament, the amount of torque required of the filament drive motor would be quadrupled. Taking this further, a motor capable of exerting four times the nominal force (in order to drive the thicker filament) is going to be far heavier than the motor driving a thinner filament. Given that the extruder is moved, often at rapid speeds, during the build, its mass should be minimized as much as possible to prevent instability and positioning error. For this reason, a thin filament (with a small diameter) is beneficial because the filament drive mechanism can be made less massive.

5.2 Control Design Considerations in Achieving More Precise Flow Control

In addition to designing the extruder itself to achieve better flow precision, the control system that runs the extruder can also be tailored to improve extrusion flow accuracy.

The first, and most trivial, way of compensating for imprecise flow rates in an FDM extruder is to match the head velocity (i.e. the speed that the extruder traverses the build platform) to the predicted flow rate of the extruder at every point in time. Assuming that we have information about the approximate dynamics and flow characteristics of the extruder from the dynamic model, it is possible to set the travel velocity of the extruder to compensate for the non-ideal flow characteristics of the extruder. A graphical representation of this control law can be

seen in Figure 7. The downside to this approach is that it necessitates depositing slower than is required in order to move the extruder-head precisely without error.

Another way of compensating for inexact flow in the extruder is to attempt to drive the extruder with a modified control signal that compensates for its inherent flow characteristics. A graphical representation of this control law can be seen in Figure 8. In this scenario the extruder could be moved at a constant velocity while the flow rate is adapted and compensates for the extruder's inherent flow characteristics.

Finally, a third way of compensating for inexact flow is to “close-the-loop.” That is to say, provide the control system with real-time measurements of the input filament diameter. This would allow the control system to react to variations in the filament diameter and avoid, as much as possible, under or over-deposition. This control law could be used in conjunction with the ones previously mentioned to mitigate both systematic and random error in the extrusion process.

[6]

6.0 CONCLUSIONS

As the fused deposition modeling process becomes increasingly used to manufacture end products (rather than just prototypes), it becomes imperative that the quality of the 3D printed objects improves. The extruder is the most logical place to focus quality improvement efforts because it is the most novel component in the process. By dynamic modeling the flow characteristics with experimental data and referencing correlations with theoretical relationships, we can target specific methods to improve flow control both in the mechanical and control design areas.

LIST OF REFERENCES

- [1] William Gurstelle. (2009, June) Boingboing. [Online].
<http://boingboing.net/2009/06/13/can-bre-pettis-repli.html>
- [2] J. Comb, W. Priederman, P. Leavitt, R. Skubic, and J. Batchelder, "High-Precision Modeling Filament," U.S. Patent 124 241, March 15, 2005.
- [3] Wikipedia. Fused Deposition Modeling. [Online].
http://en.wikipedia.org/wiki/Fused_deposition_modeling
- [4] RepRap. (2012, March) RepRap.org. [Online].
<http://reprap.org/wiki/Category:Extruders>
- [5] W. Swanson and J. Batchelder, "Filament Drive Mechanism for Use in Extrusion-Based Digital Manufacturing," U.S. Patent 7 896 209, March 1, 2011.
- [6] J. Batchelder R. Zinniel, "Volumetric Feed Control For Flexible Filament," U.S. Patent 6 085 957, July 11, 2000.
- [7] G. Selcuk, and B. Maurizio A. Bellini, "Liquifier Dynamics in Fused Deposition," *Journal of Manufacturing Science and Engineering*, vol. 126, no. 2, pp. 237-246, 2004.
- [8] Makerbot Industries. Makerbot Store - Plastic. [Online].
<http://store.makerbot.com/plastic.html>
- [9] M. Roxas and S. Ju, "Fluid Dynamics Analysis of Dektop-based Fused Deposition Modeling Rapid Prototyping," Department of Mechanical and Industrial Engineering, University of Toronto, Toronto, 2008.
- [10] P. Leavitt, and E. Rapoport J. Comb, "Velocity Profiling in an Extrusion Apparatus," U.S. Patent 6 054 077, April 25, 2000.
- [11] W. Swanson and J. Batchelder, "Liquefier Assembly for Use in Extrusion-Based Digital Manufacturing Systems," U.S. Patent 7 897 074, March 1, 2011.

FIGURES

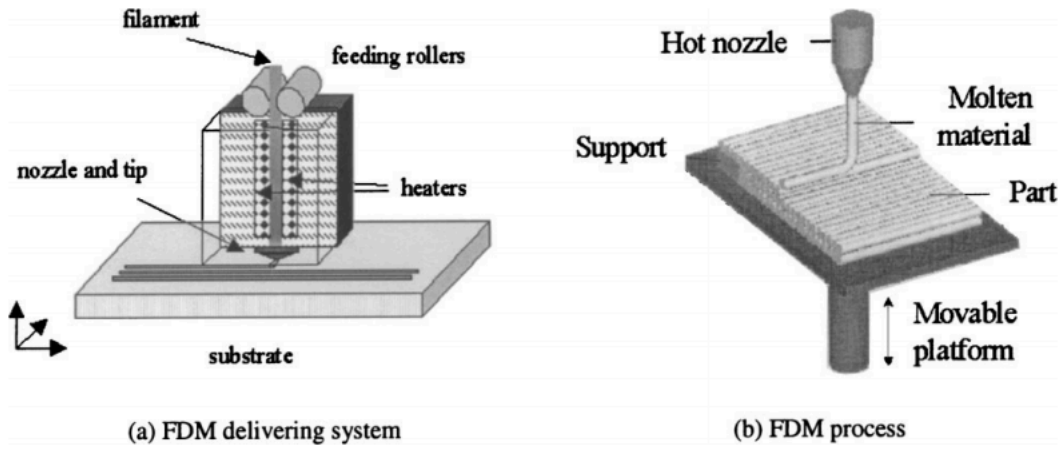

Figure 1 Visual depiction of the FDM process

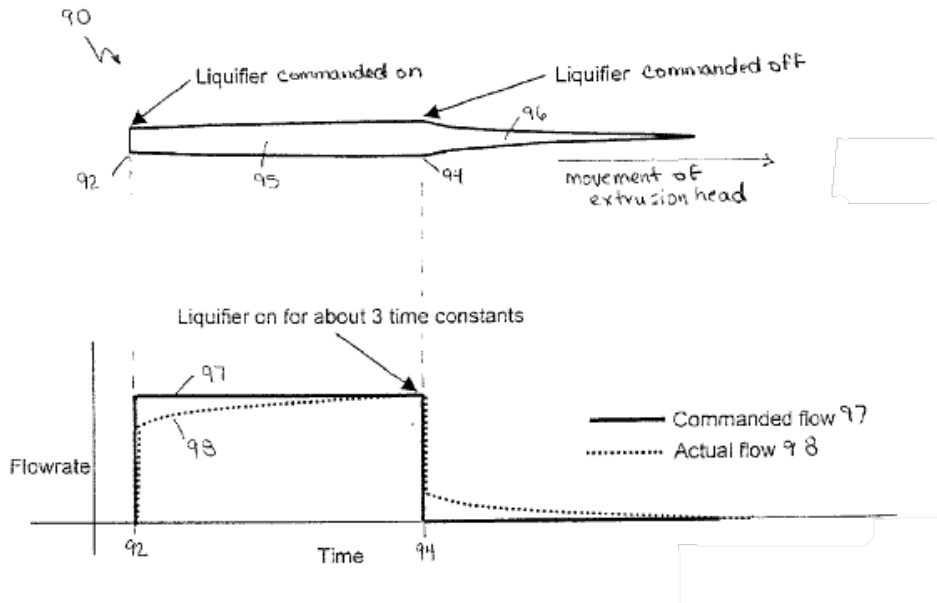

Figure 2 Stratasys drawing illustrating realistic flow characteristics of an FDM extruder

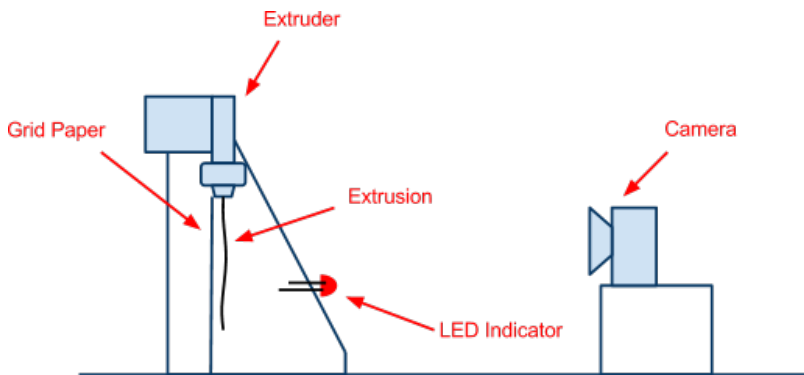

Figure 3 Experimental test setup to determine the dynamic model of a Makerbot StepStruder[®] MK6

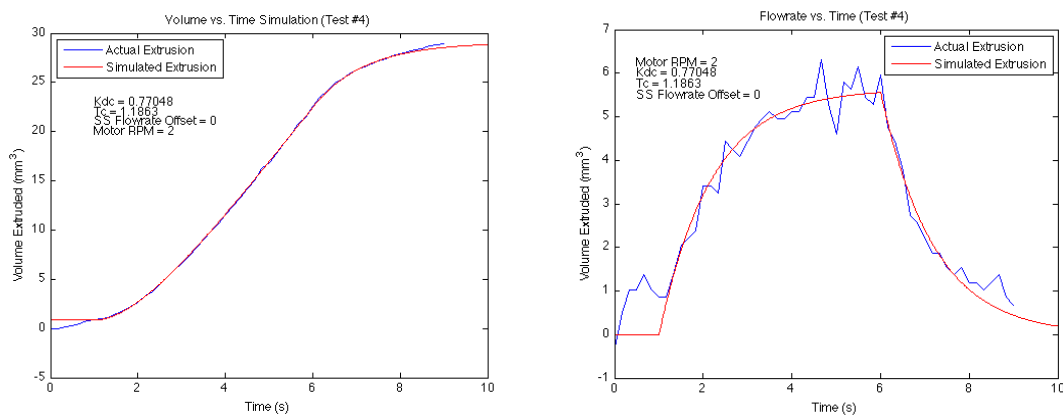

Figure 4 Experimental test data of the Makerbot StepStruder[®] MK6 with a dynamic model overlaid (Test #4). [Left] Volume vs. Time simulation, [Right] Flowrate vs. Time simulation

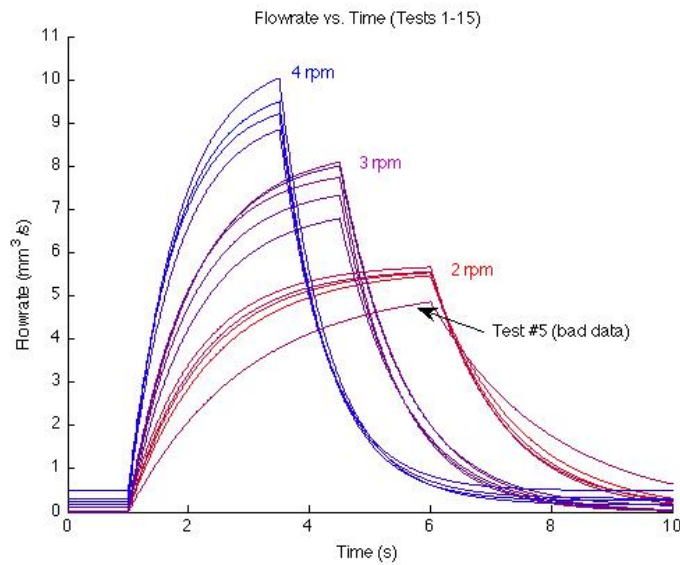

Figure 5 Plot of all fifteen dynamic model simulations derived from experimental trials with the Makerbot StepStruder[®] MK6

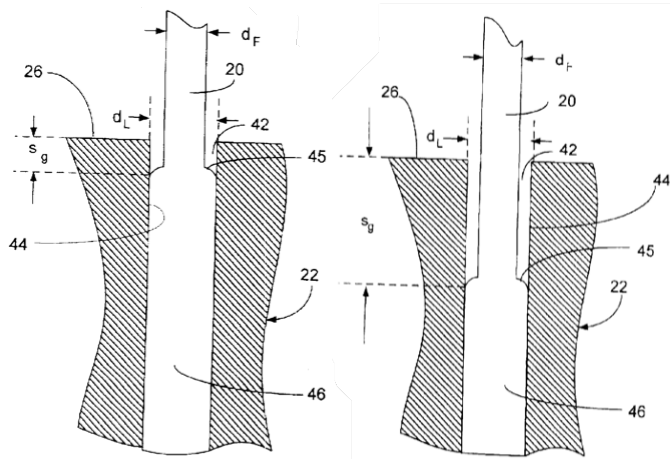

Figure 6 Stratasys Inc. drawing illustrating movement of the melt flow inside a hot-end during changes in flow rate

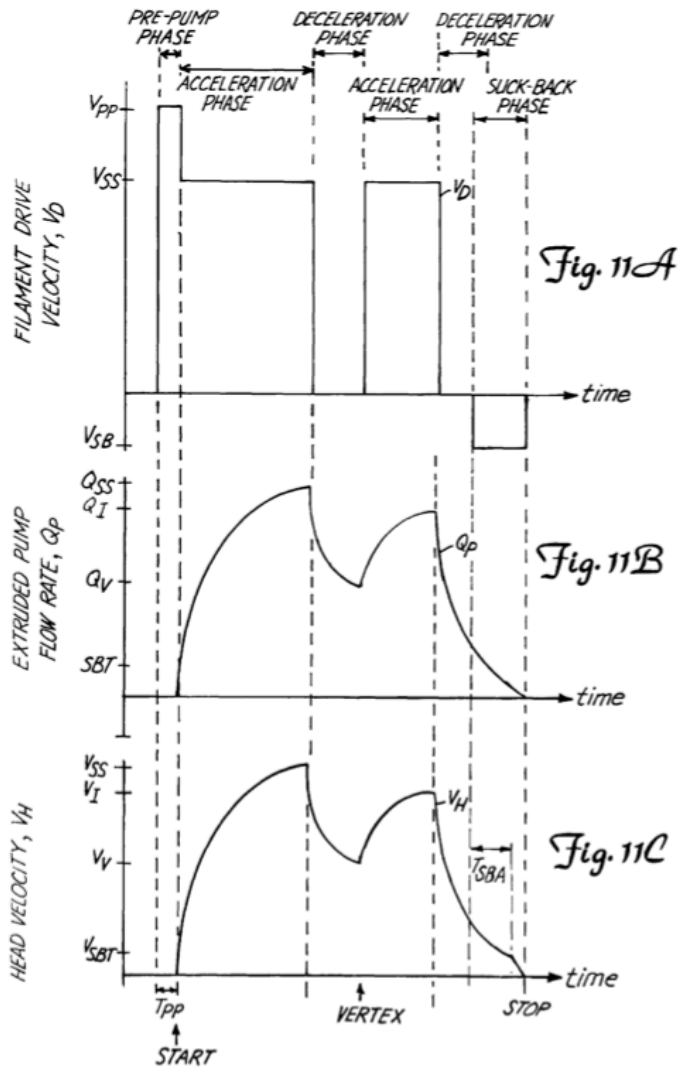

Figure 7 Stratasys graphs showing a control technique to compensate for flow characteristics

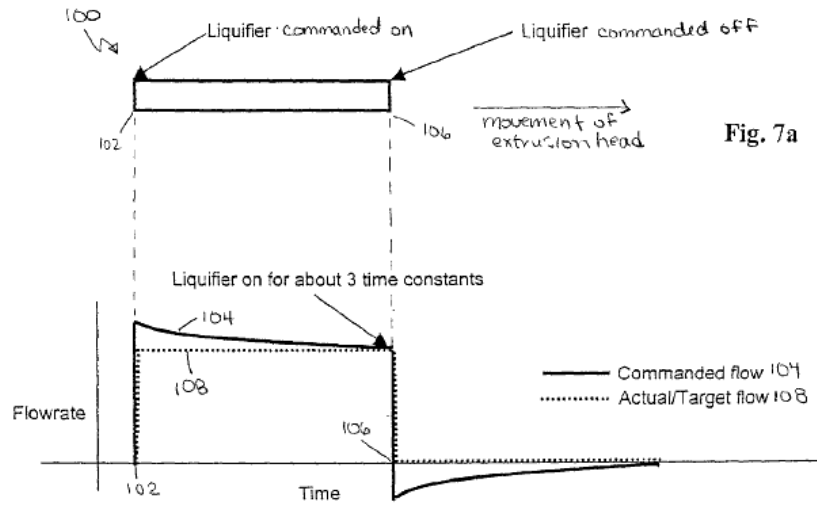

Fig. 7a

Fig. 7b

Figure 8 Stratasys graph showing an ideally compensated extrusion